

EVERY STEP OF SOLUTION



**acm**

*Industry - Bike*

ACM ALU | [www.acmendustri.com](http://www.acmendustri.com)

# EXPORT CONTRUUES



**GERMANY QATAR ITALY DUBAI**  
**SWITZERLAND SPAIN NETHERLANDS**  
**BULGARIA UZBEKISTAN BELGIUM**  
**MOROCCO FRANCE ALGERIA**  
**NIGERIA MACEDONIA UNITED KINGDOM**  
**GREECE P ALESTINE KOSOVA**  
**UNITED STATES ROMANIA**

  
**acm**  
INDUSTRY ALUMINUM

[www.acmendustri.com](http://www.acmendustri.com)



# TECHNOLOGY makes us.



## Processing profiles and sheets

*We use ultra-modern CNC processing centres.*

## Surface finishes

*We offer the ideal surface finish, whether you need a decorative or technical solution.*

## Extrusion presses

*ACM Alu produces superior-quality aluminium profiles.*

## Development and advice

*We provide support right through to the finished product. Our experienced expert technicians are with you all the way to be sure every great idea develops into a perfect solution.*

## Welding technology

*Our team of qualified professionals work under the supervision of a certified specialist welding technician to guarantee the toughest challenges are met with supreme quality craftsmanship.*

## Component group manufacture

*We produce Professional A-Z solutions. Many years of experience combine with the latest manufacturing technologies to facilitate the assembly of even the most complex bespoke structures.*

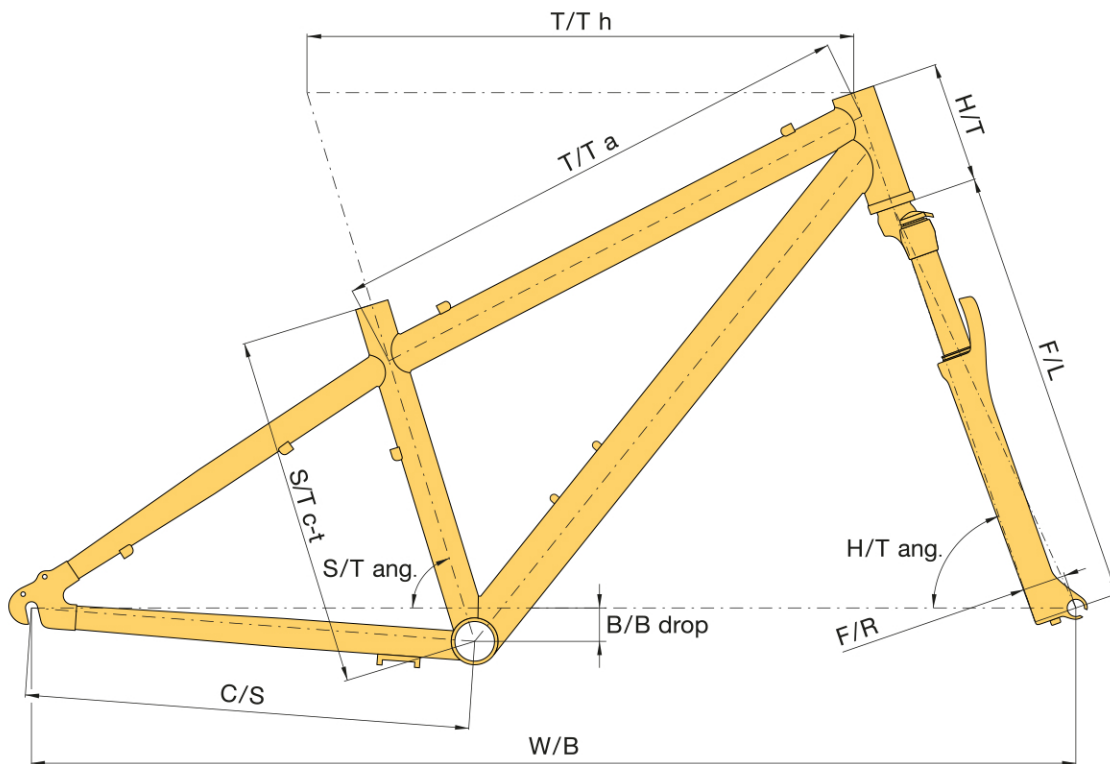

**GEOMETRY TABLE LEGEND:**

- S/T c-t** - seat tube (center-top)
- T/T h** - top tube horizontal
- T/T a** - top tube actual
- H/T** - head tube
- C/S** - chain stay
- W/B** - wheel base
- S/T ang.** - seat tube angle
- H/T ang.** - head tube angle
- F/L** - fork length
- B/B drop** - bottom bracket drop
- B/B width** - bottom bracket width
- F/R** - fork rake

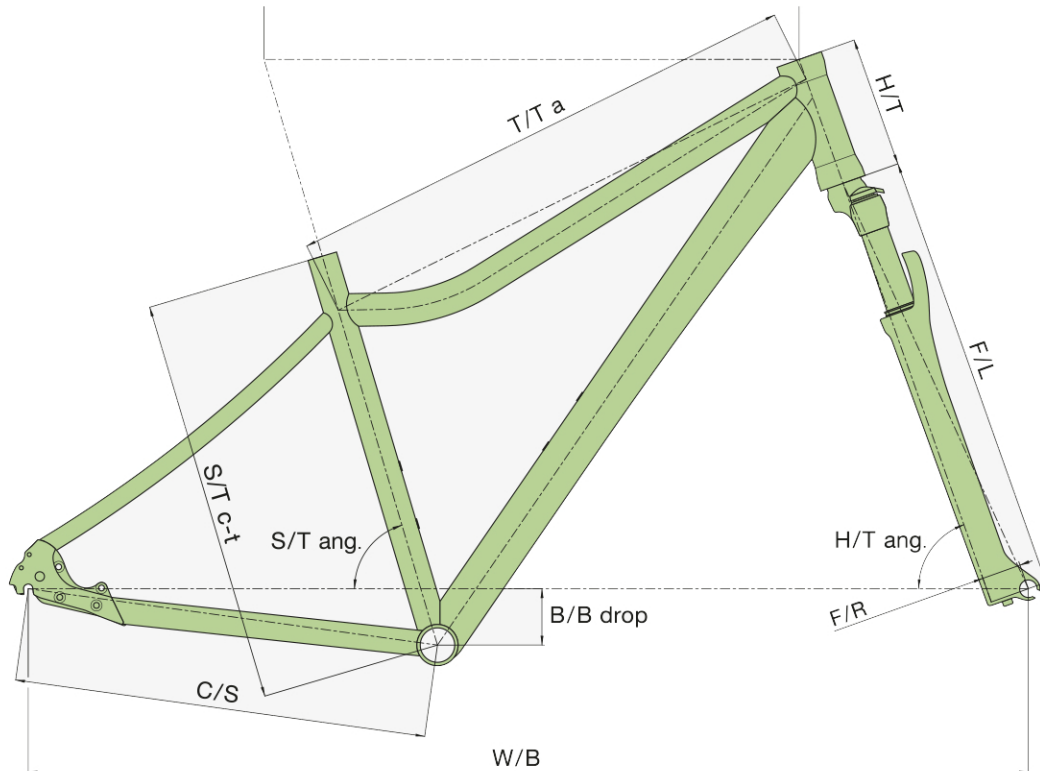

**GEOMETRY TABLE LEGEND:**

- S/T c-t** - seat tube (center-top)
- T/T h** - top tube horizontal
- T/T a** - top tube actual
- H/T** - head tube
- C/S** - chain stay
- W/B** - wheel base
- S/T ang.** - seat tube angle
- H/T ang.** - head tube angle
- F/L** - fork length
- B/B drop** - bottom bracket drop
- B/B width** - bottom bracket width
- F/R** - fork rake



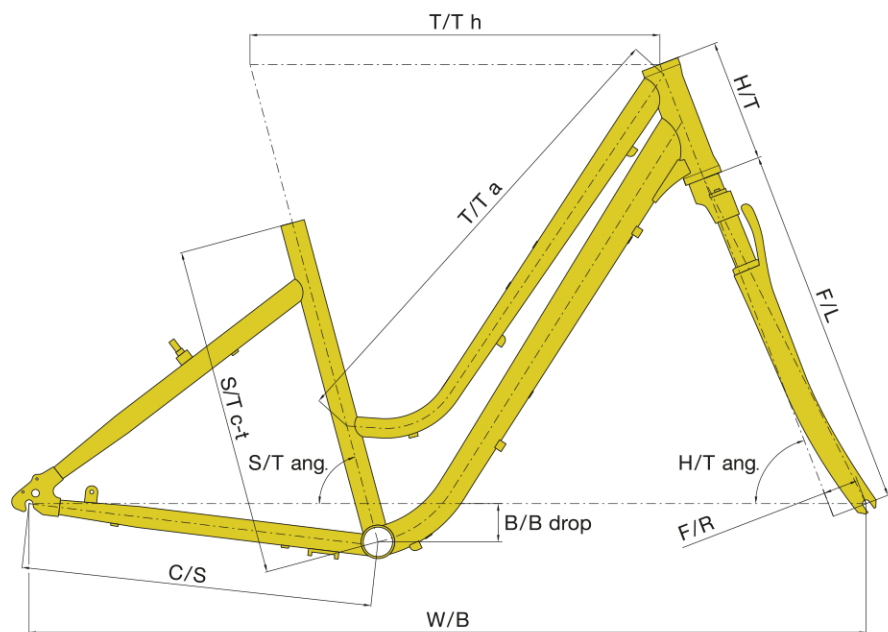
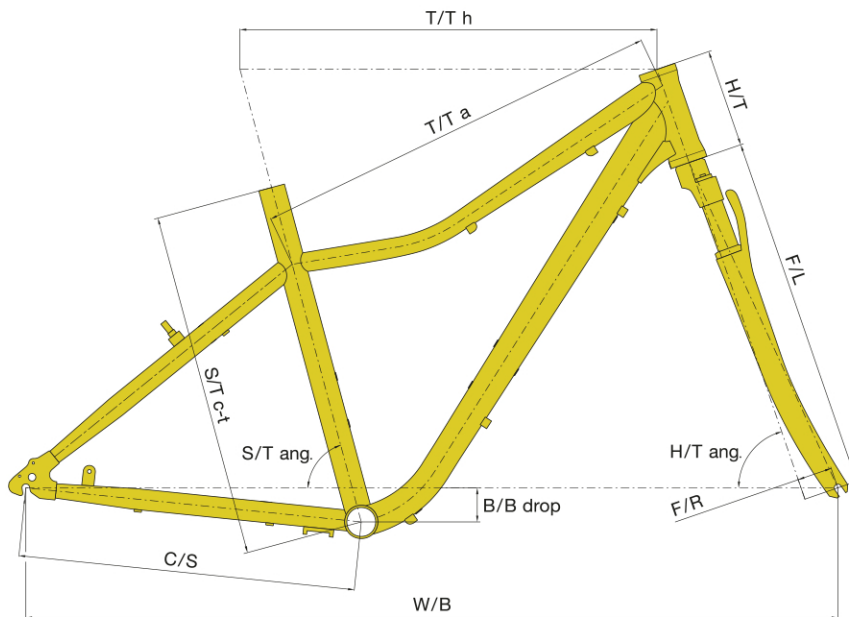

### GEOMETRY TABLE LEGEND:

- S/T c-t - seat tube (center-top)
- T/T h - top tube horizontal
- T/T a - top tube actual
- H/T - head tube
- C/S - chain stay
- W/B - wheel base
- S/T ang. - seat tube angle
- H/T ang. - head tube angle
- F/L - fork length
- B/B drop - bottom bracket drop
- B/B width - bottom bracket width
- F/R - fork rake

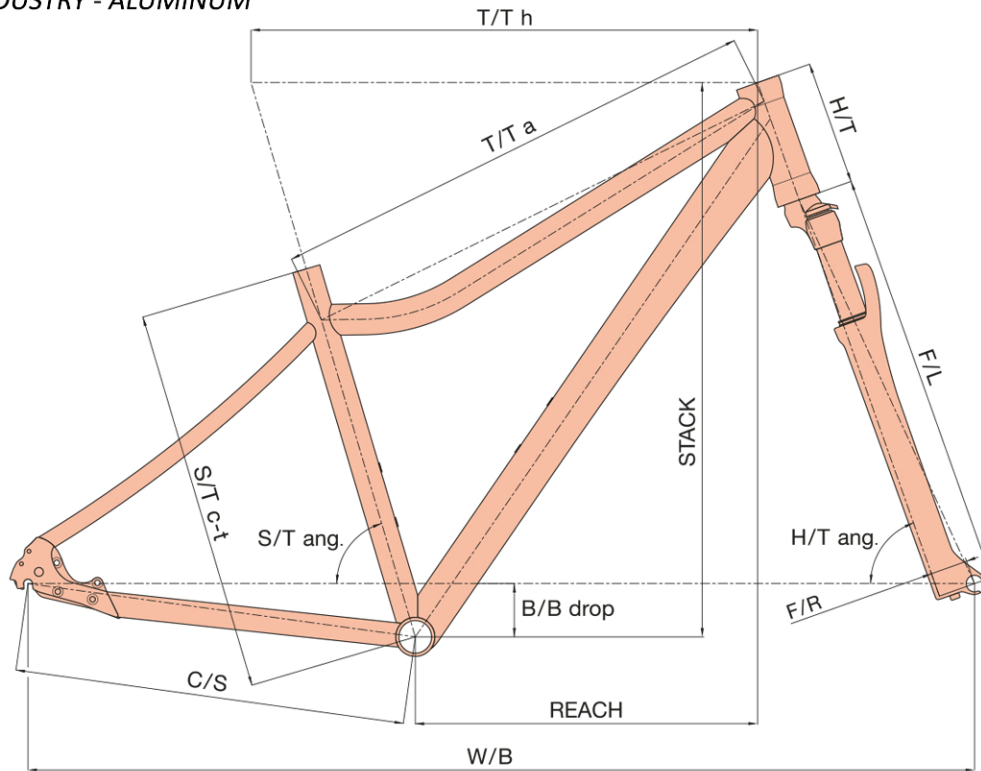

**GEOMETRY TABLE LEGEND:**

- S/T c-t** – seat tube (center-top)
- T/T h** – top tube horizontal
- T/T a** – top tube actual
- H/T** – head tube
- C/S** – chain stay
- W/B** – wheel base
- S/T ang.** – seat tube angle
- H/T ang.** – head tube angle
- F/L** – fork length
- B/B drop** – bottom bracket drop
- B/B width** – bottom bracket width
- F/R** – fork rake
- REACH** – the horizontal distance from the center of the bottom bracket / crank to the top middle point of the head tube
- STACK** – the vertical distance from the center of the frame's bottom bracket / crank to the top middle point of the head tube







## NOTES

A large rectangular area with a dashed border, containing 20 horizontal lines for writing notes.





INDUSTRY ALUMINUM

ACM ALU | [www.acmendustri.com](http://www.acmendustri.com)



*EVERY STEP OF SOLUTION*